

ANWENDUNG

- ◇ Schiffbau
- ◇ Motorenbau
- ◆ **Schienenfahrzeuge**
- ◇ Maschinenbau
- ◇ Hydraulik
- ◇ HLK
- ◇ Kältetechnik
- ◇ Prozess Techn.
- ◇ Wasseraufbereitung
- ◇ Autoindustrie
- ◇ Prüfstände
- ◇ Ex
- ◇ Lebensmittelindustrie
- ◇ Autoklaven

APPLICATIONS

- ◇ Construction navale
- ◇ Constr. de moteurs
- ◆ **Véhicules sur rail**
- ◇ Machines-outils
- ◇ Hydraulique
- ◇ CVC
- ◇ Réfrigération
- ◇ Techn. de procédés
- ◇ Traitement de l'eau
- ◇ Industrie automobile
- ◇ Banc d'essai à frein
- ◇ Ex
- ◇ Industrie alimentaire
- ◇ Autoclavage

APPLICATIONS

- ◇ Shipbuilding
- ◇ Engine manufacturing
- ◆ **Railways**
- ◇ Machine tools
- ◇ Hydraulics
- ◇ HVAC
- ◇ Refrigeration
- ◇ Process technology
- ◇ Water treatment
- ◇ Automotive industry
- ◇ Test benches
- ◇ Ex
- ◇ Food Industry
- ◇ Autoclaves



HAUPTMERKMALE

- ◆ Sensor: Dünnschicht auf Stahl
- ◆ Messbereich: 0...2.5 bis 0...600 bar
- ◆ Ausgangssignal: 4...20 mA
- ◆ NLH (BSL durch 0): ± 0.1 % d.S. typ. oder ± 0.3 % d.S. typ.

CARACTÈRES DISTINCTIFS

- ◆ Capteur: Couche mince sur acier
- ◆ Plage de mesure: 0...2.5 à 0...600 bar
- ◆ Signal de sortie: 4...20 mA
- ◆ NLH (BSL par 0): ± 0.1 % E.M. typ. ou ± 0.3 % E.M. typ.

MAIN CHARACTERISTICS

- ◆ Sensor: Thin film on steel
- ◆ Measuring range: 0...2.5 to 0...600 bar
- ◆ Signal output: 4...20 mA
- ◆ NLH (BSL through 0): ± 0.1 % FS typ. or ± 0.3 % FS typ.

VORTEILE

- ◆ erfüllt EN50155 (Eisenbahn)
Spannungsfestigkeit: 500 VAC, 50 Hz
- ◆ kompakte Bauform
- ◆ hohe Vibrationsfestigkeit
- ◆ gute Temperaturbeständigkeit
- ◆ verschiedene Genauigkeitsklassen
- ◆ komplett verschweisstes Sensorsystem aus Stahl ohne zusätzliche Dichtungen

AVANTAGES PRINCIPAUX

- ◆ remplit EN50155 (Véhicules sur rail)
rigidité diélectrique: 500 VAC, 50 Hz
- ◆ construction compacte
- ◆ grande résistance aux vibrations
- ◆ bonne résistance de température
- ◆ différente classe de précision
- ◆ système de capteur en acier complètement soudé sans joints

MAIN FEATURES

- ◆ meets EN50155 (Railways)
dielectrical strength: 500 VAC, 50 Hz
- ◆ compact design
- ◆ high resistance of vibration
- ◆ good temperature resistance
- ◆ different accuracy classes
- ◆ Completely welded steel sensor system without additional seals

BESTELLINFORMATION / INFORMATION POUR LA COMMANDE / ORDERING INFORMATION

Varianten Code/ Numéro de variantes/ Custom build code
relativ/ relatif/ relative

8293.XX.XXXX.XX.XX.XX...

Bereich	0 ... 2.5	Überdruck	max.	6	Berstdruck	100	75
Plage	0 ... 4.0	Surpression		10	Pression destruction	100	76
Range	0 ... 6.0	Over pressure		15	Burst pressure	100	77
	0 ... 10			20		200	78
	0 ... 16			32		200	79
[bar]	0 ... 25	[bar]		80	[bar]	300	80
	0 ... 40			80		300	81
	0 ... 60			200		500	82
	0 ... 100			200		500	83
	0 ... 160			500		1000	85
	0 ... 250			500		1000	74
	0 ... 400			800		1500	84
	0 ... 600			1000		2000	86

Sonderbereich nach Kundenwunsch, z. B.:
plage sur demande du client, p. ex.:
customized ranges on request, e.g.:

0 ... +12 bar

XX

Sensor	relativ, Genauigkeit/ relatif Précision/ relative Accuracy	0.3%	23
Capteur	relativ, Genauigkeit/ relatif Précision/ relative Accuracy	0.5%	25
Sensor			

Druckanschluss	G 1/4"	aussen/ mâle/ male	(O-Ring / joint torique / o-ring)	17
Raccord de pression	R1/4"	aussen/ mâle/ male		19
Pressure connection				

Ausführung	Gerätestecker/ Embase mâle / Male electrical plug	EN175301-803-A (DIN43650-A) Mat.: PA	04
Exécution			
Execution			

Ausgangssignal	Output	Load resistance	I_{SUPPLY}	U_{SUPPLY}	19
Signal de sortie	4 ... 20 mA	$(U_{supply} - 9V)/20mA$		9 ... 32 VDC	
Output					

Zubehör	Druckspitzendämpfung/ Élément d'amortissement à pointe de surpression/ Pressure peak damping element			40
Accessoires	Loch/ Trou/ Hole		ø1.0mm	43
Accessories			ø0.3mm	45
			ø0.5mm	58
	Kabeldose/ Fiche femelle/ Female electrical connector:	EN175301-803-A (DIN43650-A)/ NBR, -40...90°C		56
	Kabeldose/ Fiche femelle/ Female electrical connector:	EN175301-803-A (DIN43650-A)/ Silicon, -40...125°C		
	Anschlussbelegung spezial/ raccordement électrique spécial/ special electrical connection:			
	Output 4...20mA & Gerätestecker/ Output 4...20mA & embase mâle/ Output 4...20mA & male electrical plug			
	EN175301-803-A (DIN43650-A): Pin 1 \oplus , Pin 2 \ominus			92



Trafag entwickelt und produziert auch speziell auf Ihre Bedürfnisse zugeschnittene Produkte. Bitte fragen Sie uns an.
Trafag développe et fabrique des produits adaptés à vos besoins spécifiques en se basant sur votre cahier des charges. Contactez-nous s.v.p.
Trafag develops and manufactures customer-engineered products according to your specifications to meet your requirements. Please contact us.

SPÉZIFIKATIONEN

HAUPTMERKMALE

EN50155: integriert
Sensor: Dünnfilm auf Stahl (s. Material)
Messbereich: 0...2.5 bis 0...600 bar
Ausgangssignal: 4...20mA

GENAUIGKEIT
Messgenauigkeit 0.5%
(Bestell.-Nr. 25)

TFB @ -25...+85°C: ± 2.0 % d.S. typ.
Genauigkeit @ +25°C: ± 0.5 % d.S. typ.
NLH @ +25°C (BSL durch 0): ± 0.3 % d.S. typ.
TK Nullpunkt und Spanne: ± 0.03 % d.S./K typ.
Langzeitstabilität
1 Jahr @ +25°C: ± 0.2 % d.S. typ.

Messgenauigkeit 0.3%
(Bestell.-Nr. 23)

TFB @ -25...+85°C: ± 0.5 % d.S. typ.
Genauigkeit @ +25°C: ± 0.3 % d.S. typ.
NLH @ +25°C (BSL durch 0): ± 0.1 % d.S. typ.
TK Nullpunkt und Spanne: ± 0.005 % d.S./K typ.
Langzeitstabilität
1 Jahr @ +25°C: ± 0.2 % d.S. typ.

ELEKTRISCHE DATEN

Ausgangssignal/ Speisespannung
4...20 mA: 24 (9...32) VDC
Anstiegszeit: typ. 1 ms/10...90%
Nennndruck
Isolationswiderstand: > 10 MΩ, 500 VDC
Spannungsfestigkeit: 500 VAC, 50 Hz

UMGEBUNGSBEDINGUNGEN

Betriebstemperatur: -40...+125°C
Medientemperatur: -40...+125°C
Schutzart: IP65
Feuchtigkeit: max. 95% relativ
Vibration: 15g (20...2000 Hz)
Schock: 50g/ 11 ms

EMV-SCHUTZ

(Ausgangssignal: 4...20mA)

Emission: EN/IEC 61000-6-4
Immunity: EN/IEC 61000-6-2

MECHANISCHE DATEN

Material
Sensor: 1.4548 (AISI630)
Gehäuse: 1.4542 (AISI630) /1.4301 (AISI304)
O-Ring (medienberührend): FKM 70°Sh
Gerätestecker: siehe Bestellinformation
Anziehdrehmoment: 25 Nm
Gewicht: ~ 80...110 g

SPÉCIFICATIONS

CARACTÈRES DISTINCTIFS

EN50155: intégré
Capteur: Couche mince sur acier (voir matière)
Plage de mesure: 0...2.5 à 0...600 bar
Signal de sortie: 4...20 mA

PRÉCISION
Précision de mesure 0.5%
(No. commande 25)

TEB @ -25...+85°C: ± 2.0 % E.M. typ.
Précision @ +25°C: ± 0.5 % E.M. typ.
NLH @ +25°C (BSL par 0): ± 0.3 % E.M. typ.
CT point zéro et écart: ± 0.03 % E.M./K typ.
Stabilité à long terme
1 année @ +25°C: ± 0.2 % E.M. typ.

Précision de mesure 0.3%
(No. commande 23)

TEB @ -25...+85°C: ± 0.5 % E.M. typ.
Précision @ +25°C: ± 0.3 % E.M. typ.
NLH @ +25°C (BSL par 0): ± 0.1 % E.M. typ.
CT point zéro et écart: ± 0.005 % E.M./K typ.
Stabilité à long terme
1 année @ +25°C: ± 0.2 % E.M. typ.

SPÉCIFICATIONS ÉLECTRIQUES

Signal de sortie/ Tension d'alimentation
4...20 mA: 24 (9...32) VDC
Sensibilité de réponse: typ. 1 ms/10...90%
pression nominale
Résistive d'isolation: > 10 MΩ, 500 VDC
Rigidité diélectrique: 500 VAC, 50 Hz

CONDITIONS D'ENVIRONNEMENT

Température de service: -40...+125°C
Température de médias: -40...+125°C
Protection: IP65
Humidité: 95% max. relatif
Vibration: 15g (20...2000 Hz)
Choc: 50g/ 11 ms

CEM PROTECTION

(Signal de sortie: 4...20mA)

Emission: EN/CEI 61000-6-4
Immunité: EN/CEI 61000-6-2

SPÉCIFICATIONS MÉCANIQUES

Matériau
Capteur: 1.4548 (AISI630)
Boîtier: 1.4542 (AISI630) /1.4301 (AISI304)
O-Ring (contact. de médias): FKM 70°Sh
Embase mâle: voir information pour la
commande
Couple de serrage: 25 Nm
Poids: ~ 80...110 g

SPECIFICATIONS

MAIN CHARACTERISTICS

EN50155: integrated
Sensor: Thin film on steel (see material)
Measuring range: 0...2.5 to 0...600 bar
Signal output: 4...20 mA

ACCURACY
Measuring accuracy 0.5%
(Ordering No 25)

TEB @ -25...+85°C: ± 2.0 % FS typ.
Accuracy @ +25°C: ± 0.5 % FS typ.
NLH @ +25°C (BSL through 0): ± 0.3 % FS typ.
TC zero point and span: ± 0.03 % FS/K typ.
Long term stability
1 year @ +25°C: ± 0.2 % FS typ.

Measuring accuracy 0.3%
(Ordering No 23)

TEB @ -25...+85°C: ± 0.5 % FS typ.
Accuracy @ +25°C: ± 0.3 % FS typ.
NLH @ +25°C (BSL through 0): ± 0.1 % FS typ.
TC zero point and span: ± 0.005 % FS/K typ.
Long term stability
1 year @ +25°C: ± 0.2 % FS typ.

ELECTRICAL DATA

Output/ Supply voltage
4...20 mA: 24 (9...32) VDC
Rise time: typ. 1 ms/10...90%
nominal pressure
Resistance of insulation: >10 MΩ, 500 VDC
Dielectrical strength: 500 VAC, 50 Hz

ENVIRONMENTAL CONDITIONS

Operating temperature: -40...+125°C
Media temperature: -40...+125°C
Protection: IP65
Humidity: max. 95% relative
Vibration: 15g (20...2000 Hz)
Shock: 50g/ 11 ms

EMC PROTECTION

(Output: 4...20mA)

Emission: EN/IEC 61000-6-4
Immunity: EN/IEC 61000-6-2

MECHANICAL DATA

Material
Sensor: 1.4548 (AISI630)
Housing: 1.4542 (AISI630) /1.4301 (AISI304)
O-Ring (media contacting): FKM 70°Sh
Male electrical plug: see ordering information
Mounting torque: 25 Nm
Weight: ~ 80...110 g

Measuring accuracy 0.5%

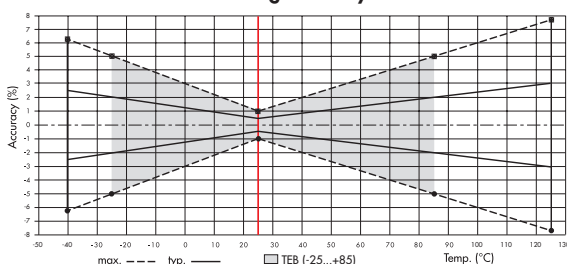

Measuring accuracy 0.3%

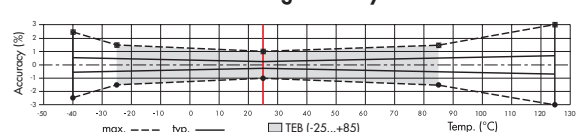

MASSBILDER / COTES D'ENCOMBREMENT / DIMENSIONS

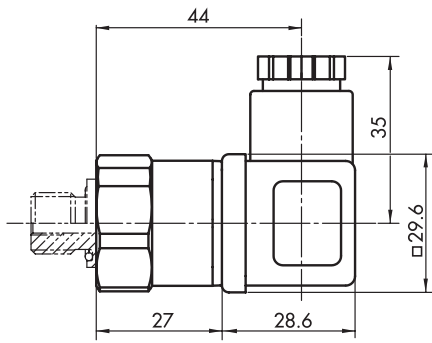

8293.XX.XXXX.04.XX.XX

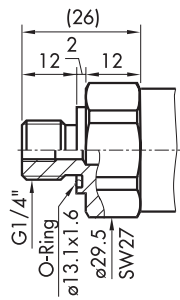

8293.XX.XX17.XX.XX

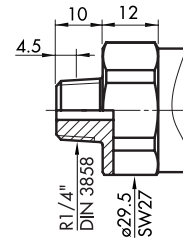

8293.XX.XX19.XX.XX

ELEKTRISCHER ANSCHLUSS / RACCORDEMENT ÉLECTRIQUE / ELECTRICAL CONNECTION

Schutzart/ Protection		IP65	
Ausführung Exécution Execution		EN175301-803-A (DIN 43650-A)	
Ausgangssignal Signal de sortie Output			
		standard	with accessory 92
8264.XX.XXXX.XX.19		2 ⊕	1 ⊕
		1 ⊖	2 ⊕