



TM1N/D is an electronic thermostat for the control of heating or cooling applications.

- * One stage, closing relay contact, 16 A, 230 V AC
- * Supply voltage 230 V or 24 V AC
- * Built-in or external setpoint
- * Adjustable night setback and hysteresis
- * Several TM1N/D can be connected to one sensor
- * Selectable between heating/cooling function

Function

TM1N/D is an electronic thermostat to be used in conjunction with Regin NTC temperature sensors. The thermostat has a changeover relay contact and is able to control *both* heating or cooling functions.

TM1N/D is supplied in standard casing for DIN-rail mounting with all settings accessible on the front.

Supply voltage

The thermostat requires supply voltage of 230 V AC or 24 V AC. See model specifications overleaf.

Sensors

The TM1N/D is intended for a sensor temperature range 0 ... 30°C, but other temperature ranges are available. See leaflet 6-100 in the *main* catalogue for choice of sensors.

TM1N/D has one output available for connection to sensor input on another TM1N/D or TM2-24/D, when several thermostats are controlled by the same sensor.

Setpoint

This is set by means of the built-in setpoint knob on the front or with an external setting device. Other scales adapted for other sensor ranges are available.

External setpoint

When using external setpoint TG-R430 or TBI-30, the built-in setpoint knob should be set at 0° thereby eliminating the effect of the built-in setpoint knob. The setpoint knob itself can be removed to avoid the danger of the setting being changed by mistake.

Hysteresis

This is set by means of the knob marked DIFF and is defined as the difference between the relay's on and off points.

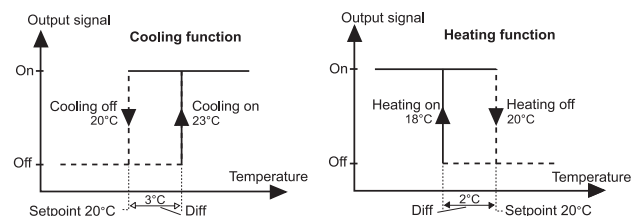

Night set-back

Night set-back can be initiated by means of an external time switch. When the time switch closes night set-back of 0...10 K from the setpoint value is obtained. Several TM1N/D can be connected to the same external time switch.

Models

TM1N/D	Electronic one-stage thermostat with supply voltage 230 V AC
TM1N-24/D	Electronic one-stage thermostat with supply voltage 24 V AC

Technical data

General

Supply voltage	230 V AC +/- 15% 50-60 Hz or 24 V AC +/- 15% 50-60Hz
Power consumption	Max. 2 VA
Ambient temperature	0 ... 50°C
Storage temperature	-40 ... +50°C
Ambient humidity	Max. 90%RH
Form of protection	IP20



This product conforms with the requirements of European EMC standards CENELEC EN50081-1 and EN 50082-1, European LVD standards IEC 669-1 and IEC 669-2 and carries the CE mark.

Inputs

Sensor	For Regin NTC sensors. See leaflet 6-100 for choice of sensor.
Setpoint	When using an external setpoint the setpoint device should be connected in series with the sensor to the sensor input.
Night set-back	For potential free closing contact from external time switch.

Outputs

Relay contact	One 16 A 230 V AC, closing contact
Sensor signal	Output for connecting to another TM1N/D sensor input

Settings

Setpoint	0...30°C, Setpoint
DIFF	0... 10 K, Hysteresis
NIGHT SETBACK	0... 10 K, Night setback
HEAT-COOL	Choice of heating or cooling function

Indications

Supply voltage	Red LED
Relay output	Red LED comes on when relay is activated

Wiring and dimensions

TM1N/D

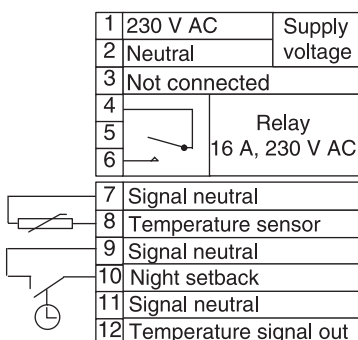

Terminal 2 - neutral and terminal 7, 9, 11 - signal neutral are not connected internally.

TM1N-24/D

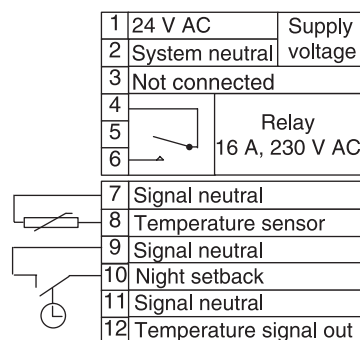

Terminal 2 - neutral and terminal 7, 9, 11 - signal neutral are connected internally.

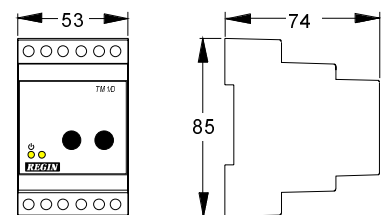

Measurements in mm

FOR INDOOR CLIMATE WITH OPTIMUM CONTROL

AB Regin

Box 116, SE-428 22 Källered, Sweden
Visiting address: Bangårdsvägen 35

Phone: +46 31 795 44 60
Fax: +46 31 795 38 50

www.regin.se
E-mail: info@regin.se

Org.nr.: SE556414-5455
Säte: Mölndal