

EP2032

32 DI Multifunction PIFA

Multifunction PIFA with 32 digital inputs for mounting in an EXOflex house.

- 32 DI for alarm management, run-time indications, pulse counting etc.

- 4 DI with advanced functions (e.g. pulse counting, frequency measuring etc.) and standard functions
- 28 DI with standard functions, e.g. filtering, on-/off-delay, run-time measurement

EP2032 is a multifunction PIFA with 32 DI.

EXOflex

EXOflex is a general system for control, regulation, supervision and communication in general automation installations. The system offers great possibilities when constructing many different types of control and regulation systems: outstations in distributed systems, controllers in building automation systems, service gateways in LANs and on the Internet, etc.

The system is of a modular design and provides unique opportunities for adapting the number and type of inputs and outputs required, as well as the type of communication needed.

EXOflex consists of a housing and a selection of PIFA units. One power-PIFA must always be present in each house.

Installation

EP2032 can generally be mounted in any of the compartments in an EXOflex house. It is of a standard design and size and can quickly and simply be slotted into place.



All electrical connections to external equipment are easily attainable on plug-in screw connectors.

For more information on how to install PIFA:s, see the instruction for EH11...41 / EH10...40 / ECX1.

EP2032 handles difficult electrical environments

The process connections are, as a group, galvanically insulated from each other and from the internal control logic circuits by a protective barrier, which is bridged by optocouplers. If necessary, the isolation from other circuits can be retained by using a separate power supply. Each process connection has active transient protection, which is led to a special EMI ground (disturbance protection ground) or to protective ground. This provides for optimal handling of difficult electrical environments.

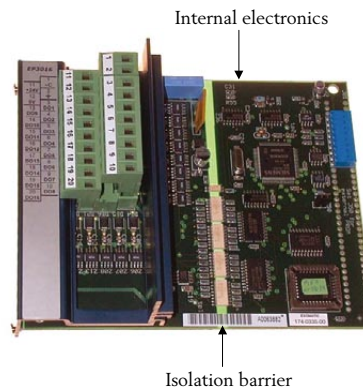

The principles of the isolation barrier

Prepared for redundant power supply

The parts of the PIFA closest to the process get their power from an external source, which is normally the same as the source supplying the whole EXOflex-unit with power. To handle power outage situations, it could also be power supplied from an alternative source, e. g. 9035 with external battery. See the product sheets for EP1011 and 9035.

Connections

EP2032 has 32 digital inputs of the electric type Standard 24 V DC DI. The last four inputs are of the Software Advanced type and are preferably used for pulse counting, if this is required. The first 28 are of the type Software Normal.

The last four inputs can also be used as S0 inputs for connecting certain energy meters, etc. EP2032 is designed for general applications. Potential-free contacts are typically used as input sensors.

- **Power supply**

The EMI earth must be connected to the earth rail or equivalent, to prevent disturbances.

The 0 V connection must also be grounded. This is normally done at the power unit's negative pole.

- **Standard 24 V DC DI**

This type of input is used for reading of floating (potential free) contacts and is active high.

A yellow LED for each input shows its current status.

Process Connections

The external contact's one end is connected to the input and the other to +C. The +C output is current limited and short circuit proof.

Technical data

Supply voltage	24 V DC
tolerance	18...30 V DC
electronically fused	to 250 mA
power consumption with no load	0
+C output for DI, level	= Supply voltage
max load	fused with electronic fuse, 250 mA
Internal Power Consumption	5 V, 60 mA



This product conforms with the requirements of European EMC standards CENELEC EN 61000-6-1 and EN 61000-6-3 and carries the CE-mark.

Digital inputs

Number of inputs	32
Type inputs 1–28	Normal
Type inputs 29–32	Advanced
Logic 0	0...5 V
input current at 0 V	0 mA
input resistance	5.7 kOhm
Logic 1	11...30 V
input current at +24 V	4 mA
Shortest pulse length for detection	
software type normal	9 ms
software type advanced	4.5 ms

Digital input 29-32 activated as type 2 inputs (S0 inputs)

The last four inputs can individually be activated as so-called S0 inputs by using a jumper on the PIFA card. S0 inputs, sometimes referred to as Type 2 inputs, have a somewhat different electrical specification than standard, see below.

Logic 0	0...5 V
input current at 0 V	0 mA
input resistance	5.7 kOhm
Logic 1	11...30 V
input current at +24 V	15 mA

Connections

Pin no	Signal	Function
1	+C	+24 V DC. Output for analog inputs AI and digital inputs DI.
2	EMI ground	This terminal is connected internally to the PIFA's frame and to internal protective circuits. It should be connected to the ground rail with a separate, heavy wire.
3	DI1	Digital input 1, type Standard 24 V DC
4	DI2	Digital input 2, type Standard 24 V DC
5	DI3	Digital input 3, type Standard 24 V DC
6	DI4	Digital input 4, type Standard 24 V DC
7	DI5	Digital input 5, type Standard 24 V DC
8	DI6	Digital input 6, type Standard 24 V DC
9	DI7	Digital input 7, type Standard 24 V DC
10	DI8	Digital input 8, type Standard 24 V DC
11	DI9	Digital input 9, type Standard 24 V DC
12	DI10	Digital input 10, type Standard 24 V DC
13	DI11	Digital input 11, type Standard 24 V DC
14	DI12	Digital input 12, type Standard 24 V DC
15	DI13	Digital input 13, type Standard 24 V DC
16	DI14	Digital input 14, type Standard 24 V DC
17	DI15	Digital input 15, type Standard 24 V DC
18	DI16	Digital input 16, type Standard 24 V DC
19	+24 V	Power supply +24 V DC.
20	0 V	Power supply 0 V. The 0 V-connection is normally grounded at the supply source, so as to define the potential to earth reference and to compensate for disturbances and transients from I/O signals.
21	DI17	Digital input 17, type Standard 24 V DC
22	DI18	Digital input 18, type Standard 24 V DC
23	DI19	Digital input 19, type Standard 24 V DC
24	DI20	Digital input 20, type Standard 24 V DC
25	DI21	Digital input 21, type Standard 24 V DC
26	DI22	Digital input 22, type Standard 24 V DC
27	DI23	Digital input 23, type Standard 24 V DC
28	DI24	Digital input 24, type Standard 24 V DC
29	DI25	Digital input 25, type Standard 24 V DC
30	DI26	Digital input 26, type Standard 24 V DC
31	DI27	Digital input 27, type Standard 24 V DC
32	DI28	Digital input 28, type Standard 24 V DC
33	DI29	Digital input 29, type Standard 24 V DC
34	DI30	Digital input 30, type Standard 24 V DC
35	DI31	Digital input 31, type Standard 24 V DC
36	DI32	Digital input 32, type Standard 24 V DC

Product documentation

Document	Type
EH11...41 / EH10...40 / ECX1	Instruction for EXOflex houses and the EXOflex processor ECX1
EXO System Manual 2005	Manual covering the EXO System

Head Office Sweden
 Phone: +46 31 720 02 00
 Web: www.regin.se
 Mail: info@regin.se

Sales Offices
 France: +33 14 171 46 46
 Hong Kong: +852 24 07 02 81
 Singapore: +65 67 47 82 33



THE CHALLENGER IN BUILDING AUTOMATION