

# EP6012

## 12 AO Voltage Multifunction PIFA

PIFA for mounting in an EXOflex house, with 12 standard AO for control of frequency controlled pumps, engines etc.

- 11 bits resolution
- Outputs 0...10 V DC

- Scaling factor, offset, ramp generation, override possibility
- Configurable function at power-up and error events

EP6012 is a PIFA with 12 analog outputs of the type Standard AO.

### EXOflex

EXOflex is a general system for control, regulation, supervision and communication in general automation installations. The system offers great possibilities when constructing many different types of control and regulation systems: outstations in distributed systems, controllers in building automation systems, service gateways in LANs and on the Internet, etc.

The system is of a modular design and provides unique opportunities for adapting the number and type of inputs and outputs required, as well as the type of communication needed.

EXOflex consists of a housing and a selection of PIFA units. One power-PIFA must always be present in each house.

### Installation

EP6012 can generally be mounted in any of the compartments in an EXOflex house. It is of a standard design and size and can quickly and simply be slotted into place.



All electrical connections to external equipment are easily attainable on plug-in screw connectors.

For more information on how to install PIFA:s, see the instruction for EH11...41 / EH10...40 / ECX1.

### EP6012 handles difficult electrical environments

The process connections are, as a group, galvanically insulated from each other and from the internal control logic circuits by a protective barrier, which is bridged by optocouplers. If necessary, the isolation from other circuits can be retained by using a separate power supply. Each process connection has active transient protection, which is led to a special EMI ground (disturbance protection ground) or to protective ground. This provides for optimal handling of difficult electrical environments.

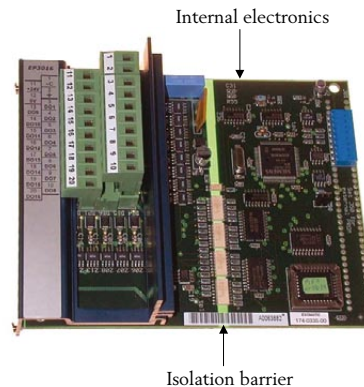

The principles of the isolation barrier

### Prepared for redundant power supply

The parts of the PIFA closest to the process get their power from an external source, which is normally the same as the source supplying the whole EXOflex-unit with power. To handle power outage situations, it could also be power supplied from an alternative source, e. g. 9035 with external battery. See the product sheets for EP1011 and 9035.

## Connections

- **Power supply**

The EMI earth must be connected to the earth rail or equivalent, to prevent disturbances.

The 0 V connection must also be grounded. This is normally done at the power unit's negative pole.

- **Standard AO**

Each output is current limited and short circuit proof. This type of output is mainly intended for use with damper motors, shunt valves, frequency inverters and other analog actuators for 0...10 V.

### Process Connections

Normal, high-ohm loads are connected between the output and AGnd. Other types of loads for special applications with low-ohm loads are best connected between the output and 0 V (terminal 16).

## Technical data

|                            |  |
|----------------------------|--|
| Supply voltage             | 24 V DC  |
| tolerance                  | 18...30 V DC   |
| power consumption          | max load: electronically fused to 200 mA, no load: 90 mA   |
| Internal power consumption | 5 V, 50 mA   |
| <b>CE</b>                  | This product conforms with the requirements of European EMC standards CENELEC EN 61000-6-1 and EN 61000-6-3 and carries the CE-mark. |

## Analog outputs

|                               |  |
|-------------------------------|--|
| Number of outputs             | 12   |
| Basic resolution              | 11 bits  |
| Output range                  | 0 to 10 V  |
| accuracy                      | ±0.2% ±20 mV at > 1000 Ohms load                   |
| Max current                   |  |
| on one output                 | 20 mA, 10 V/500 Ohm                                |
| on all outputs simultaneously | 40 mA, with 24 V stabilized supply voltage: 110 mA |

## Connections

| Pin no | Signal     | Function  |
|--------|------------|---|
| 1      |            |   |
| 2      | EMI ground | This terminal is connected internally to the PIFA's frame and to internal protective circuits. It should be connected to the ground rail with a separate, heavy wire. |
| 3      | AO1        | Analog output 1, type Standard  |
| 4      | AO2        | Analog output 2, type Standard  |
| 5      | AGnd       | Reference pole for AO1 and AO2  |
| 6      | SCR        | Connection for screen, AO1 and AO2  |
| 7      | AO3        | Analog output 3, type Standard  |
| 8      | AO4        | Analog output 4, type Standard  |
| 9      | AGnd       | Reference pole for AO3 and AO4  |
| 10     | SCR        | Connection for screen, AO3 and AO4  |
| 11     | AO5        | Analog output 5, type Standard  |
| 12     | AO6        | Analog output 6, type Standard  |
| 13     | AGnd       | Reference pole for AO5 and AO6  |
| 14     | SCR        | Connection for screen, AO5 and AO6  |

| Pin no | Signal | Function   |
|--------|--------|--|
| 15     | +24 V  | Power supply + 24 V DC   |
| 16     | 0 V    | Power supply 0 V. The 0 V-connection is normally grounded at the supply source, so as to define the potential to earth reference and to compensate for disturbances and transients from I/O signals. |
| 17     | AO7    | Analog output 7, type Standard   |
| 18     | AO8    | Analog output 8, type Standard   |
| 19     | AGnd   | Reference pole for AO7 and AO8   |
| 20     | SCR    | Connection for screen, AO7 and AO8   |
| 21     | AO9    | Analog output 9, type Standard   |
| 22     | AO10   | Analog output 10, type Standard  |
| 23     | AGnd   | Reference pole for AO9 and AO10  |
| 24     | SCR    | Connection for screen, AO9 and AO10  |
| 25     | AO11   | Analog output 11, type Standard  |
| 26     | AO12   | Analog output 12, type Standard  |
| 27     | AGnd   | Reference pole for AO11 and AO12   |
| 28     | SCR    | Connection for screen, AO11 and AO12   |

## Analog output connections

For high-ohm loads, analog output voltages are referenced relative to AGnd. For low-ohm loads, use the 0 V terminal (16) as reference pole.

Analog output voltages are referenced relative to AGnd. EP6012 has a connection for screened cables for analog outputs. The connection is SCR.

|      |                                       |
|------|---------------------------------------|
| AGnd | Reference pole for analog outputs AO. |
| SCR  | Connection for screen.                |

## Product documentation

| Document  | Type   |
|---|--|
| EH11...41 / EH10...40 / ECX1 EXO System Manual 2005 | Instruction for EXOflex houses and the EXOflex processor ECX1 Manual covering the EXO System |

**Head Office Sweden**  
 Phone: +46 31 720 02 00  
 Web: [www.regin.se](http://www.regin.se)  
 Mail: [info@regin.se](mailto:info@regin.se)

**Sales Offices**  
 France: +33 14 171 46 46  
 Hong Kong: +852 24 07 02 81  
 Singapore: +65 67 47 82 33

 **REGIN**

THE CHALLENGER IN BUILDING AUTOMATION